

**NOTE: All Assembly Order Numbers are for bead plate parts unless noted otherwise.**

	Description	Assembly Order No.
Style 1T19L-7	Blind nuts, 1/4 NPT	W01-358-9148
	Blind nuts, 1/4 NPT, bumper	W01-358-9149
Two Ply Bellows	Blind nuts, 3/4 NPT	W01-358-9172
	Blind nuts, 3/4 NPT, bumper	W01-358-9160
	Countersunk steel bead ring 1 3/4 bolts, nuts, washers	W01-358-9165
Assembly weight .....		11.16 kg.

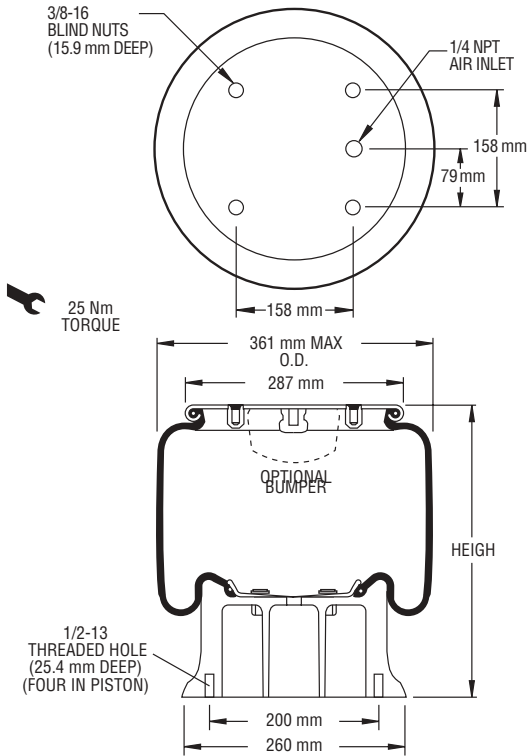

**NOTE: Bellows will not compress properly with less than .7 BAR internal pressure.**

**NOTE: A bead plate part is shown. This part is also available with a bead ring. Bolts are not included. See pages 8-10 for explanation.**

Dynamic Characteristics at 380 mm Design Height (Required for Airmount isolator design only)			
Gauge Pressure (BAR)	Load (kN)	Spring Rate (kN/m)	Natural Frequency Hz
3	16.82	98	1.20
4	22.64	128	1.18
5	28.37	155	1.17
6	34.49	186	1.16
7	40.18	215	1.15

CONSULT FIRESTONE BEFORE USING AS AIRMOUNT

RECOMMENDED AIRMOUNT DESIGN HEIGHT 380 mm.

**Static Data**  
0308

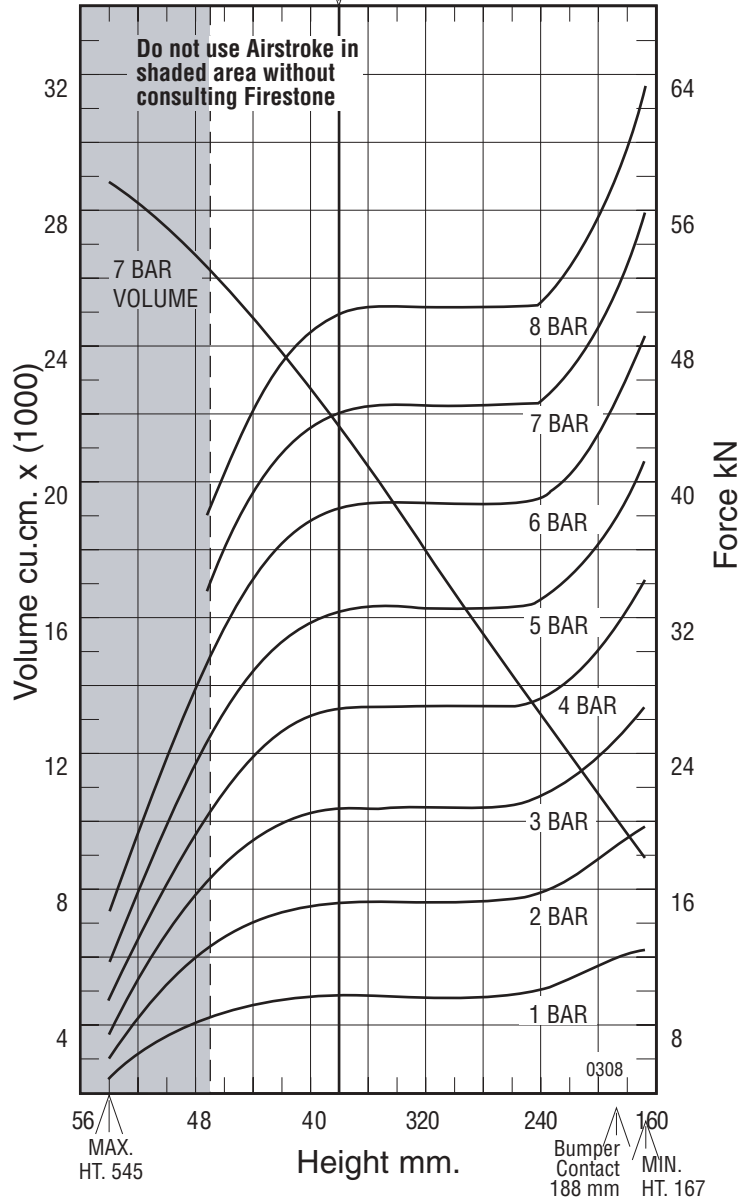

See page 12 for instructions on how to use chart.

**Force Table (Use for Airstroke® actuator design)**

Assembly Height (mm)	Volume @ 7 BAR (cu cm)	EFF Area @ 7 BAR (cm sq)	kN Force				
			@ 3 BAR	@ 4 BAR	@ 5 BAR	@ 6 BAR	@ 7 BAR
460	23795	454	13.44	17.70	22.22	27.17	31.77
420	21800	536	15.94	21.20	26.54	32.23	37.53
380	19624	574	16.82	22.64	28.37	34.49	40.18
340	17263	580	16.84	22.78	28.56	34.78	40.56
300	14779	580	16.84	22.78	28.56	34.78	40.56
260	12355	580	16.85	22.78	28.56	34.78	40.56
220	9981	606	18.44	24.34	30.28	36.48	42.38
180	7648	698	21.43	28.27	35.08	42.10	48.84