

NOTE: All Assembly Order Numbers are for bead plate parts unless noted otherwise.

	Description	Assembly Order No.
Style 1T14C-1	Blind nuts, 1/4 NPT	W01-358-5310
	Blind nuts, 1/4 NPT, bumper	W01-358-5311
Two Ply Bellows	Blind nuts, 3/4 NPT	W01-358-5305
	Blind nuts, 3/4 NPT, bumper	W01-358-5306
	Countersunk steel bead ring 1 3/4 bolts, nuts, washers	W01-358-5307
Assembly weight.....		2.95 kg.

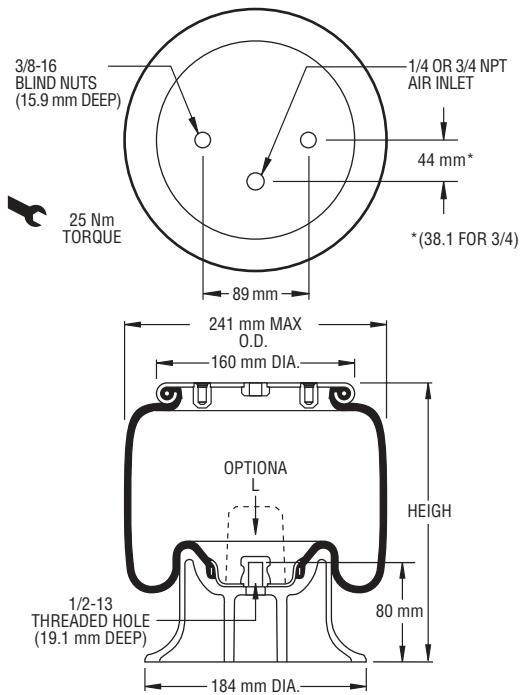

NOTE: Bellows will not compress properly with less than .7 BAR internal pressure.

NOTE: A bead plate part is shown. This part is also available with a bead ring. Bolts are not included. See pages 8-10 for explanation.

Gauge Pressure (BAR)	Load (kN)	Spring Rate (kN/m)	Natural Frequency Hz
3	5.88	47	1.41
4	8.06	67	1.44
5	10.14	83	1.43
6	12.41	102	1.43
7	14.50	117	1.42

CONSULT FIRESTONE BEFORE USING AS AIRMOUNT

RECOMMENDED AIRMOUNT DESIGN HEIGHT 255 mm.

Static Data
3019

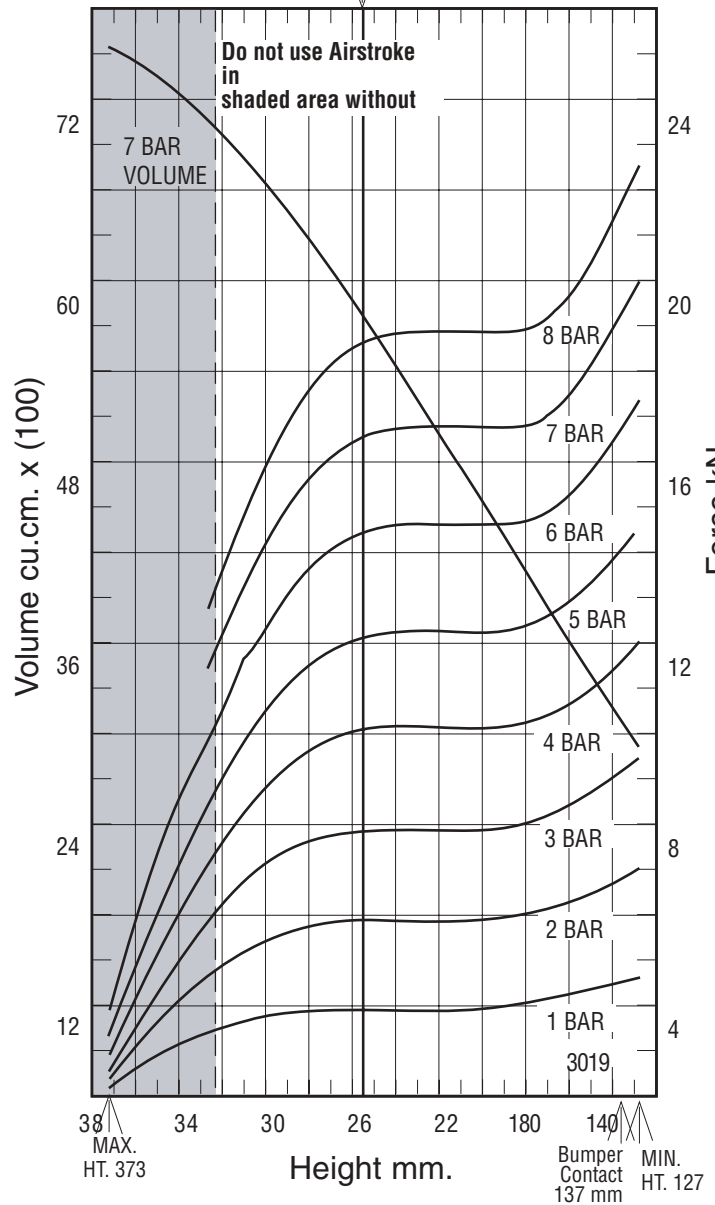

See page 12 for instructions on how to use chart.

Assembly Height (mm)	Volume @ 7 BAR (cu cm)	EFF Area @ 7 BAR (cm sq)	kN Force				
			@ 3 BAR	@ 4 BAR	@ 5 BAR	@ 6 BAR	@ 7 BAR
300	6065	171	5.05	6.70	8.39	10.23	11.94
280	5704	192	5.62	7.45	9.45	11.52	13.45
260	5306	205	5.86	8.00	10.06	12.30	14.36
240	4881	210	5.89	8.15	10.28	12.60	14.73
220	4438	211	5.89	8.15	10.29	12.63	14.76
200	3967	211	5.89	8.15	10.29	12.63	14.76
180	3494	211	5.98	8.19	10.32	12.63	14.76
160	3027	220	6.39	8.59	10.80	13.18	15.37