

**NOTE: All Assembly Order Numbers are for bead plate parts unless noted otherwise.**

	Description	Assembly Order No.
Style 116-1	Blind nuts, 1/4 BSP	W01-M58-6170
Two Ply Bellows		
Assembly weight.....		2.04 kg.
Force to collapse to minimum height (@ 0 BAR)		165 N.

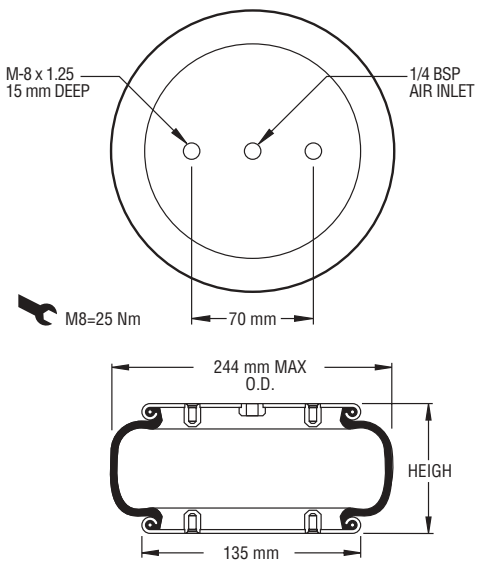

**NOTE: A bead plate part is shown. This part is also available with bead rings. See pages 8-10 for explanation.**

Gauge Pressure (BAR)	Load (kN)	Spring Rate (kN/m)	Natural Frequency Hz
3	4.45	108	2.46
4	5.94	138	2.41
5	7.52	170	2.37
6	9.42	205	2.33
7	11.18	237	2.30

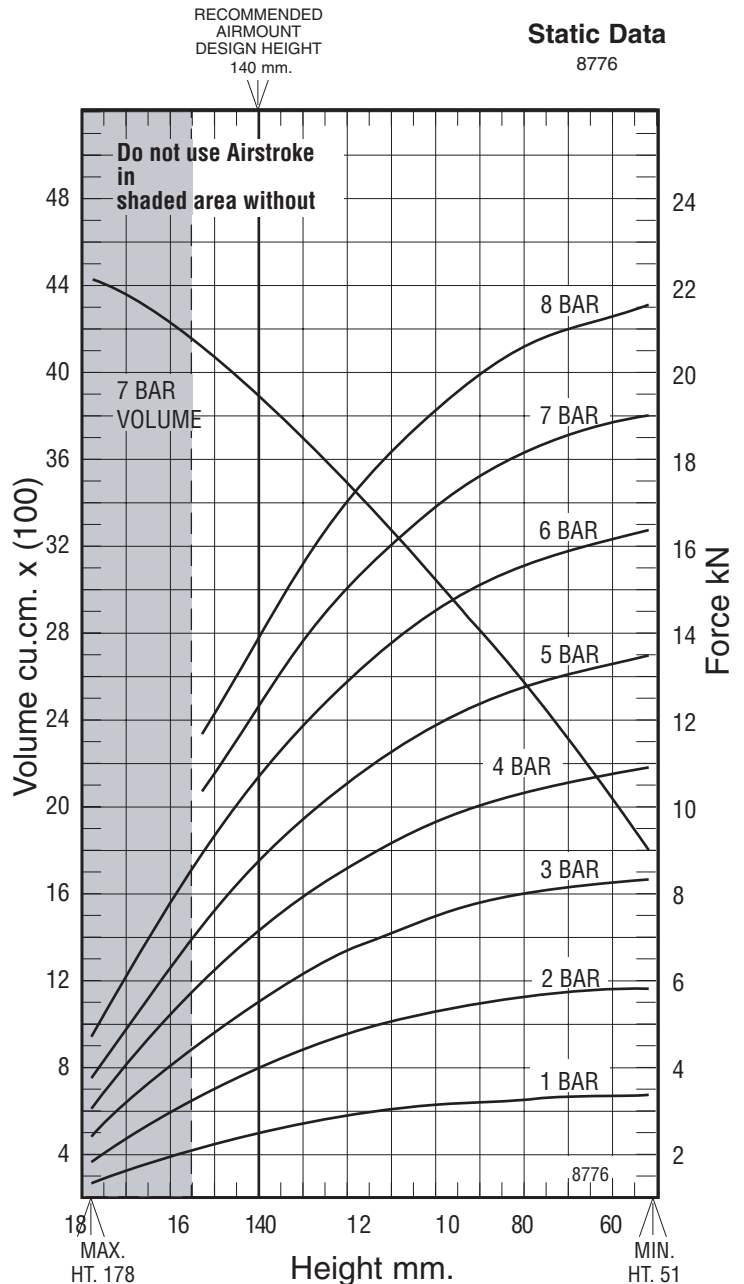

See page 12 for instructions on how to use chart.

Assembly Height (mm)	Volume @ 7 BAR (cu cm)	EFF Area @ 7 BAR (cm**2)	kN Force				
			@ 3 BAR	@ 4 BAR	@ 5 BAR	@ 6 BAR	@ 7 BAR
140	3678	160	4.45	5.94	7.52	9.42	11.18
130	3491	180	5.08	6.77	8.55	10.66	12.61
120	3301	197	5.61	7.47	9.42	11.71	13.82
110	3085	213	6.07	8.06	10.18	12.63	14.89
100	2869	225	6.44	8.54	10.79	13.38	15.75
90	2628	236	6.76	8.94	11.31	14.02	16.49
80	2391	244	7.00	9.25	11.72	14.51	17.05
70	2130	250	7.19	9.51	12.05	14.91	17.50