

Description		Assembly Order No.
Style 1T15M-6	Blind nuts, 1/4 NPT	WO1-358-9079
	Blind nuts, 1/4 NPT, bumper	WO1-358-9096
Two Ply Bellows	Blind nuts, 3/4 NPT	WO1-358-9089
	Blind nuts, 3/4 NPT, bumper	WO1-358-9088
	Blind nuts, 3/4 NPT (piston not included)	WO1-358-0730
Assembly weight (bead plate version, no bumper)..... 15.7 lbs.		

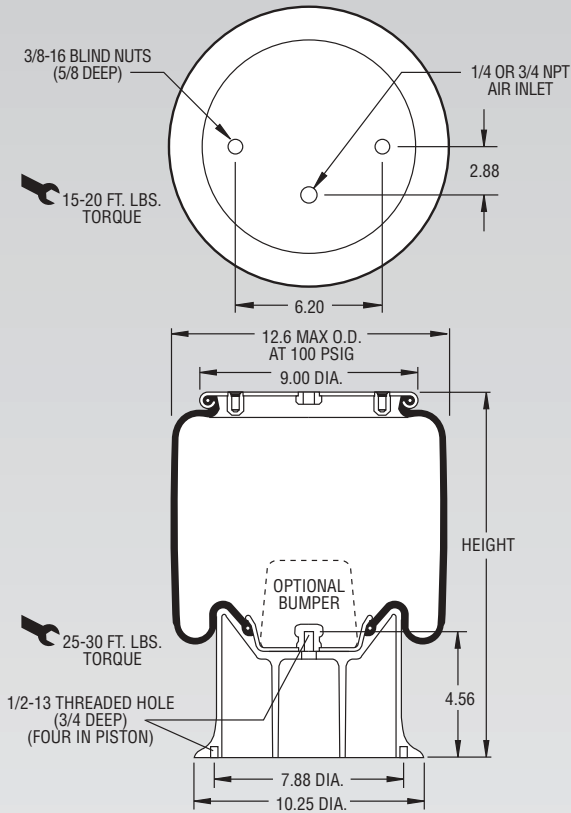

**NOTE:** Bellows will not compress properly with less than 10 PSIG internal pressure.

**NOTE:** A bead plate part is shown. This part is also available with a bead ring. Bolts are not included. See pages 8-10 for explanation.

Dynamic Characteristics at 15.0 in. Design Height (Required for Airmount isolator design only)				
Volume @ 100 PSIG = 1,060 in <sup>3</sup>			Natural Frequency	
Gage Pressure (PSIG)	Load (lbs.)	Spring Rate (lbs./in.)	CPM	HZ
40	2,720	395	71	1.19
60	4,110	541	68	1.13
80	5,560	707	67	1.12
100	7,000	852	65	1.09

CONSULT FIRESTONE BEFORE USING AS AIRMOUNT

RECOMMENDED AIRMOUNT DESIGN HEIGHT 15.0 INCHES

**Static Data**  
4452

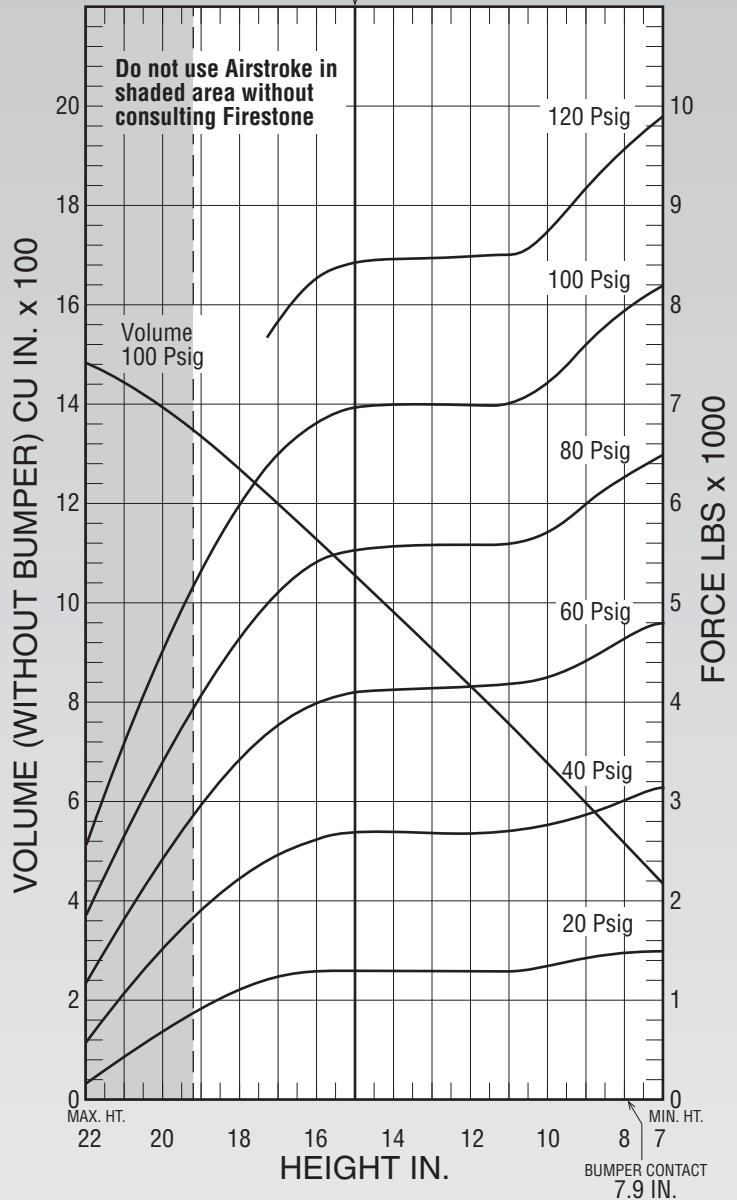

See page 12 for instructions on how to use chart.

Force Table (Use for Airstroke® actuator design)						
Assembly Height (in.)	Volume @ 100 PSIG (in <sup>3</sup> )	Pounds Force				
		@20 PSIG	@40 PSIG	@60 PSIG	@80 PSIG	@100 PSIG
18.0	1,274	1,100	2,220	3,420	4,670	5,980
16.0	1,134	1,290	2,640	4,000	5,410	6,840
14.0	987	1,330	2,730	4,130	5,590	7,030
12.0	841	1,330	2,710	4,170	5,590	7,010
10.0	693	1,380	2,790	4,270	5,730	7,240
8.0	533	1,500	3,060	4,670	6,280	7,950