**WARNING!**

Do not inflate this assembly when it is unrestricted. The assembly must be restricted by the suspension or other adequate structure. Do not inflate beyond 100 P.S.I. Improper use or over inflation may cause property damage or severe personal injury.

INSTALLATION INSTRUCTIONS

Congratulations - your new Air Helper Springs are quality products capable of improving the handling and comfort of your vehicle. As with all products, proper installation is the key to obtaining all of the benefits your kit is capable of delivering. Please take a few minutes to read through the instructions to identify the components and learn where and how they are used. It is a good idea to start by comparing the parts in your kit with the parts list below.

The heart of the Air Helper Spring kit is, of course, the air helper springs. Remember that the air helper springs must flex and expand during operation, so be sure that there is enough clearance to do so without rubbing against any other part of the vehicle.

Be sure to take all applicable safety precautions during the installation of the kit. The instructions listed in this brochure and the illustrations all show the right, or passenger's side of the vehicle. To install the left side assembly, simply follow the same procedures.

Your kit includes separate inflation valves and air lines for each air helper spring. This will allow you to level your vehicle from side to side as well as from front to back. If you would rather have a single valve inflation system, your dealer can supply the required "T" fitting.

IMPORTANT!

For your safety and to prevent possible damage to your vehicle, do not exceed the maximum load recommended by the vehicle manufacturer (GVWR). Although your Air Helper Springs are rated at a maximum inflation pressure of 100 P.S.I., this pressure may allow you to carry too great a load on some vehicles. Check your vehicle owner's manual for maximum loads listed for your vehicle.

When inflating your Air Helper Springs, add air pressure in small quantities, checking pressure frequently during inflation. The air spring requires much less air volume than a tire and, therefore, inflates much more quickly.

PARTS LIST

AIR SPRING	9001	2	5/16" -18 x 3-1/2" HEX BOLT	2
UPPER BRACKET (RIGHT)	5261	1	5/16" -18 FLANGED HEX NUT	2
UPPER BRACKET (LEFT)	5262	1	PUSH-TO-CONNECT	
LOWER BRACKET	5263	2	ELBOW FITTING	3101 2
BRACKET STRAP	5086	2	PUSH-TO-CONNECT	
ROUND PLATE	5204	2	INFLATION VALVE	3098 2
3/8" -16 x 1-1/2" HEX BOLT		6	VALVE CAP	3099 2
3/8" -16 x 3/4" FLANGED HEX BOLT		6	5/16" FLAT WASHER	4
3/8" -16 FLANGED HEX NUT		14	18 FT. AIR LINE TUBING	1
3/8" -16 x 3" CARRIAGE BOLT		8	THERMAL SLEEVE	2
3/8" FLAT WASHER		6	NYLON TIE	6

NOTE: Both illustrations are of the right, or passenger's side, of the vehicle. Reverse any orientations when installing the left, or driver's side assembly.

FIGURE "A"

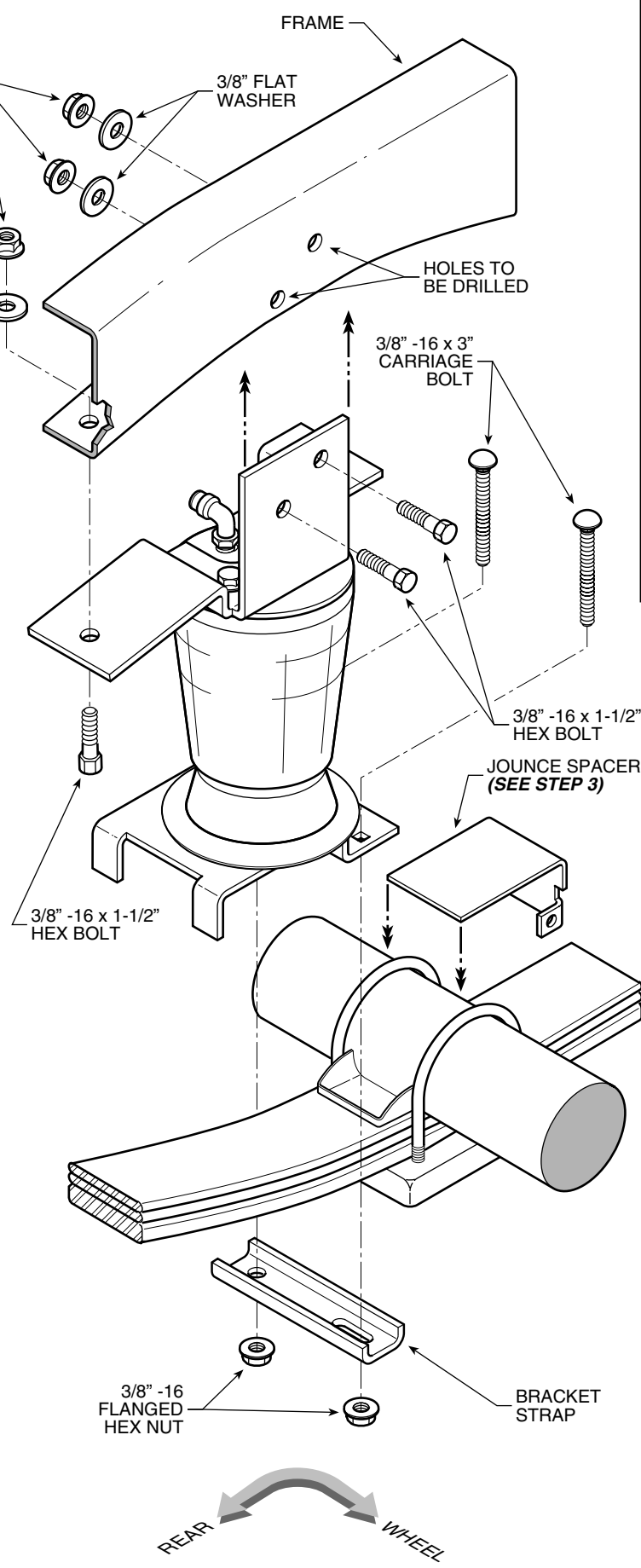
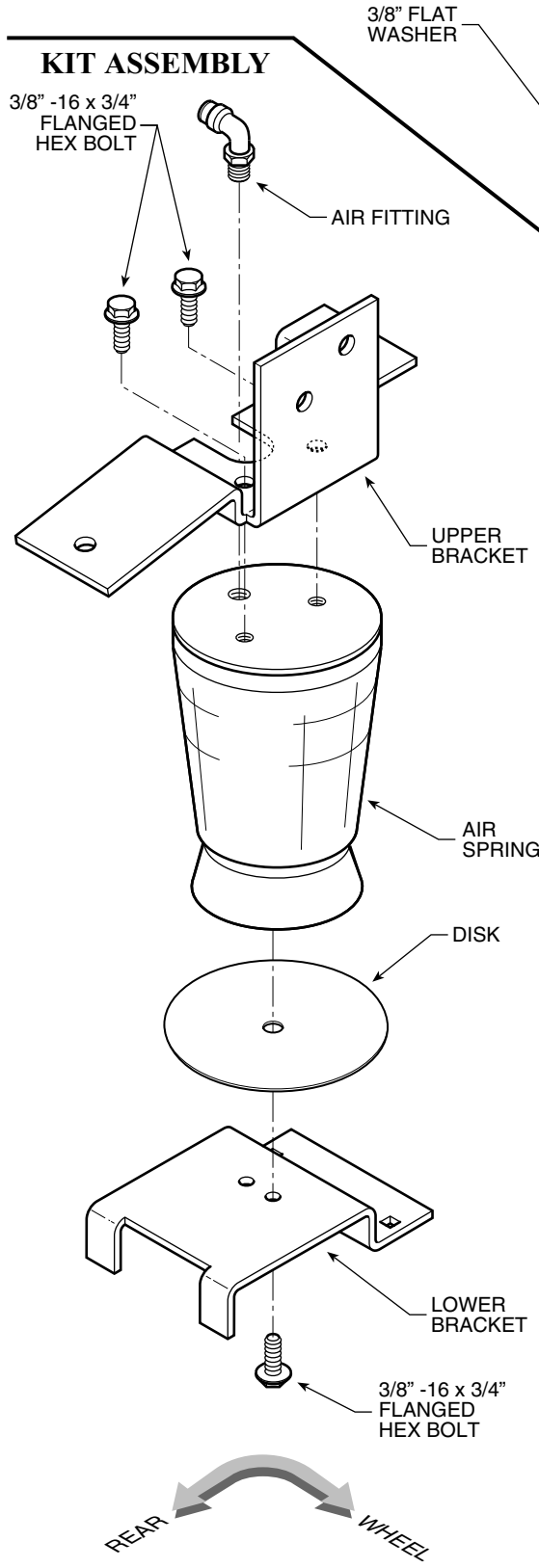

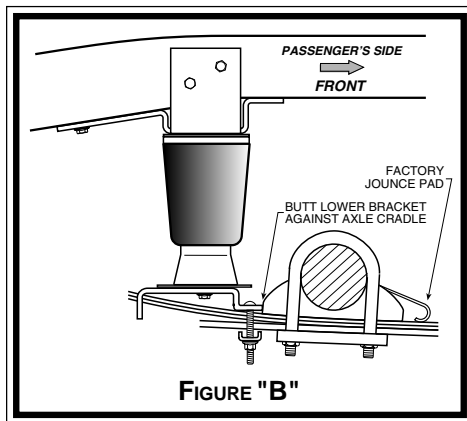

FIGURE "B"

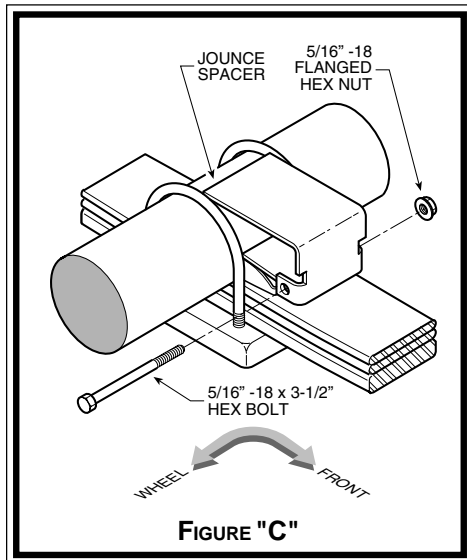

FIGURE "C"

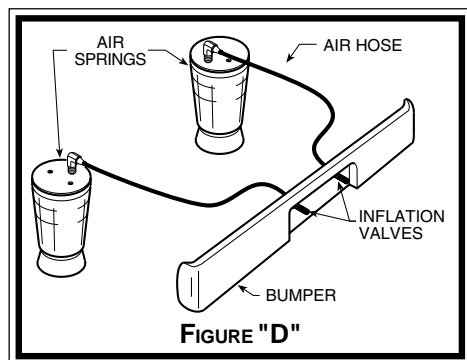

FIGURE "D"

STEP 1 - PREPARE THE VEHICLE

Remove the negative battery cable. With the vehicle on a solid, level surface chock the front wheels. Raise the vehicle by the axle and remove the rear wheels. After the removal of the wheels lower the vehicle so the axle rests on jack stands rated to support your vehicle's weight.

STEP 2 - PREASSEMBLE THE KIT

Pre-assembly will begin with the right (passenger's) side of the vehicle. All pictures show the installation on the right side of the vehicle unless noted otherwise. Select an air spring and the right-hand upper bracket from your kit *see Figure "A"*. Align the holes in the top of the air spring with the mounting holes in the upper bracket, making sure the air inlet hole is visible through the slot in the bracket. Secure the bracket to the air spring using two 3/8" -16 x 3/4" flanged hex bolts *see Figure "A"*. Next, install the air fitting through the slot in the upper bracket and into the air spring. Tighten the air fitting so as to make contact with the nylon ring and then tighten 1/4 turn to snug the fitting. No thread sealant is required on the air fitting. Select a lower bracket from your kit. Insert two 3/8" -16 x 3" carriage bolts through the square holes in the lower bracket. Align the mounting hole in the lower bracket *as shown in Figure "A"* with the hole in the bottom of the air spring. Install the disk between the bottom of the air spring and the lower bracket. Fasten the lower bracket to the air spring using a 3/8" -16 x 3/4" flanged hex bolt (*finger tight*).

STEP 3 - INSTALL THE ASSEMBLY TO THE VEHICLE

Position the air spring assembly on top of the leaf spring just behind the axle. The lower bracket must be butted against the axle cradle *see Figure "B"*. It may be necessary to compress the air spring assembly to properly position the upper bracket. On some models, there is a hole in the bottom of the frame flange that will line up with the hole in the tab on the upper bracket. Insert a 3/8" -16 x 1-1/2" hex bolt through the hole in the slanted tab of the upper bracket and the hole in the bottom of the frame rail (if applicable). Install a 3/8" washer and 3/8" -16 flanged hex nut on the bolt *see Figures "A" & "B"*. If this hole is not available on your vehicle, orient the upper bracket so that the air spring is as close to vertical as possible. The upper bracket should be seated against the bottom of the frame rail.

Using the holes in the vertical tab of the upper bracket as a template, drill two 13/32" holes through the side of the frame rail. *Hint: Once the locations of the holes has been marked, drilling can be made easier by first drilling a 1/8" diameter hole then finishing with a 13/32" drill bit.* Attach the upper bracket to the frame rail by inserting two 3/8" -16 x 1-1/2" hex bolts through the upper bracket and frame rail and secure them with two 3/8" -16 hex nuts and 3/8" flat washes *see Figure "A"*. When drilling through the frame, make sure that all brake, electrical, and fuel lines will clear the path of the drill on the inside the frame rail. A block of wood placed between the inside of the frame and the lines can help to avoid damaging these lines while drilling. Slide the bracket strap over the carriage bolts and against the

bottom of the leaf spring. Secure the bracket strap to the lower bracket with two 3/8" -16 flanged hex nuts. Tighten the 3/8" -16 hex bolt securing the air spring to the lower bracket.

Your air helper spring kit includes a jounce spacer bracket. Install this bracket on the leaf spring, just forward of the axle *see Figures "A" & "B"*. Insert a 5/16" -18 x 3-1/2" hex bolt through the holes in the jounce spacer, underneath the factory jounce pad, and secure with a 5/16" -18 hex nut.

STEP 4 - INSTALL THE DRIVER'S SIDE ASSEMBLY

Follow steps 2 and 3 for the installation of the driver's side assembly. Reverse any orientations when assembling and installing the air spring on the driver's side of the vehicle.

STEP 5 - INSTALL THE AIR LINE AND INFLATION VALVE

Uncoil the air tubing and cut it in two equal lengths. *DO NOT FOLD OR KINK THE TUBING.* Make the cut as square as possible. Insert one end of the tubing into the push-to-connect elbow fitting installed in the top of the air helper spring as far as possible.

Select a location on the vehicle for the air inflation valves. The location can be on the bumper or the body of the vehicle, as long as it is in a protected location so the valve will not be damaged, but still maintain accessibility for the air chuck *see Figure "D"*. Drill a 5/16" hole and install the air inflation valve using two 5/16" flat washers per valve as supports *see Figure "E"*. Run the tubing from the air helper spring to the valve, routing it to avoid direct heat from the engine, exhaust pipe, and away from sharp edges. Thermal sleeves have been provided for these conditions. The air line tubing should not be bent or curved sharply as it may buckle. Secure the tubing in place with the nylon ties provided. Push the end of the air line tubing into the inflation valve *see Figure "E"*.

STEP 6 - CHECK THE AIR SYSTEM

Once the inflation valves are installed, inflate the air helper springs to 70 P.S.I. and check the fittings for air leaks with an applied solution of soap and water. If a leak is detected at a tubing connection, check to make sure that the tube is cut as squarely as possible and that it is pushed completely into the fitting. The tubing can easily be removed from the fittings. First, release the air pressure from the air springs. Push the collar towards the body of the fitting and then pull out the tube. If a leak is detected where the air fitting screws into the air spring, remove the tubing, then tighten the air fitting in the air spring until the leak stops. Reinstall the tubing and reinflate the air springs and check for leaks as noted above.

This now completes the installation. Before proceeding, check once again to be sure you have proper clearance around the air springs. With a load on your vehicle and the air helper springs inflated, you must have at least 1/2" clearance around the air springs. As a general rule, the Air Helper Springs will support approximately 30 lbs. of load for each psi of inflation pressure (per pair). For example, 50 psi of inflation pressure will support a load of 1500 lbs. per pair of air helper springs. *FOR BEST RIDE* use only enough air pressure in the air helper springs to level the vehicle when viewed from the side (front to rear). This amount will vary depending on the load, location of load, condition of existing suspension and personal preference.

NOTE:

Too much air pressure in the air helper springs will result in a firmer ride, while too little air pressure will allow the air helper spring to bottom out over rough conditions. Too little air pressure will also not provide the possible improvement in handling. ***TO PREVENT POSSIBLE DAMAGE, MAINTAIN A MINIMUM OF 10 P.S.I. IN THE AIR HELPER SPRINGS AT ALL TIMES.***

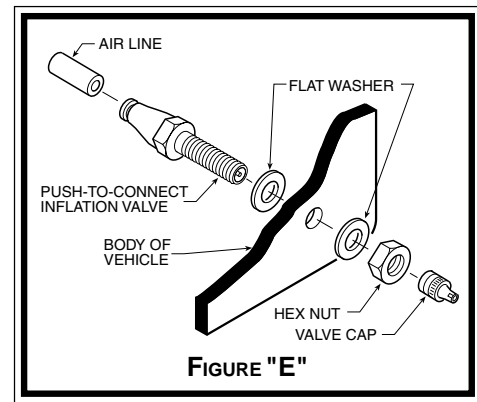

NOTE:

Once the air helper springs are installed, it is recommended that the vehicle not be lifted by the frame, as over-extension may occur, resulting in damage to the air helper springs. However, should it become necessary to raise the vehicle by the frame, deflate both air helper springs completely.