**WARNING:**

Do not inflate this assembly when it is unrestricted. The assembly must be restricted by the suspension or other adequate structure. Do not inflate beyond 100 P.S.I. Improper use or over inflation may cause property damage or severe personal injury.

Firestone Industrial Products
Carmel, Indiana, USA

INSTALLATION INSTRUCTIONS

Congratulations - your new Sport-Rite Air Helper Springs are quality products capable of improving the handling and comfort of your vehicle. As with all products, proper installation is the key to obtaining all of the benefits your kit is capable of delivering. Please take a few minutes to read through the instructions to identify the components and learn where and how they are used. It is a good idea to start by comparing the parts in your kit with the parts list below.

The heart of the Sport-Rite kit is, of course, the air helper springs. Remember that the air helper springs must flex and expand during operation, so be sure that there is enough clearance to do so without rubbing against any other part of the vehicle.

Be sure to take all applicable safety precautions during the installation of the kit.

Your kit includes separate inflation valves and air lines for each air helper spring. This will allow you to level your vehicle from side to side as well as from front to back. If you would rather have a single valve inflation system, your dealer can supply the required "T" fitting.

IMPORTANT!

For your safety and to prevent possible damage to your vehicle, do not exceed the maximum load recommended by the vehicle manufacturer (GVWR). Although your Sport-Rite Air Helper Springs are rated at a maximum inflation pressure of 100 P.S.I., this pressure may allow you to carry too great a load on some vehicles. Check your vehicle owner's manual for maximum loads listed for your vehicle.

When inflating your Sport-Rite Air Helper Springs, add air pressure in small quantities, checking pressure frequently during inflation. The air spring requires much less air volume than a tire and, therefore, inflates much quicker.

PARTS LIST

AIR SPRINGS	9002	2	3/8" SPECIAL FLAT WASHERS	7
RIGHT UPPER BRACKET	5209	1	3/8" SPECIAL WASHERS	1
LEFT UPPER BRACKET	5208	1	3/8"-16 X 3.5" CARRIAGE BOLTS	4
LOWER BRACKETS	5218	2	5/16" FLAT WASHERS	4
DISK	5204	2	PUSH TO CONNECT	
BRACKET STRAPS	5086	2	INFLATION VALVES	3032 2
AIR LINE TUBING		1	PUSH TO CONNECT	
3/8"-16 X 1-1/2" HEX BOLTS		8	FITTINGS	3046 2
3/8"-16 FLANGE LOCK NUTS		12	NYLON TIES	6
3/8"-16 X 3/4" FLANGED HEX BOLTS		6		

Note: The kit assembly illustration shown to the right is of the right, or passengers side, of the vehicle. Reverse any orientations when assembling the kit on the left, or drivers, side of the vehicle.

Kit to frame assembly

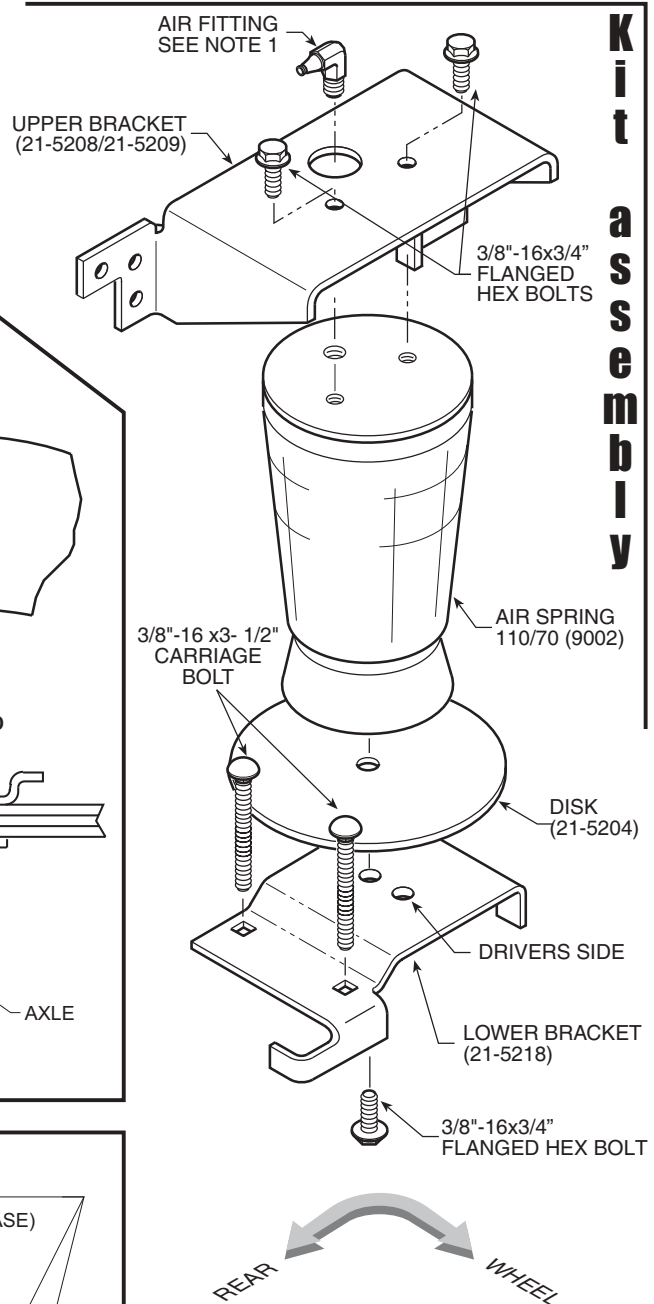
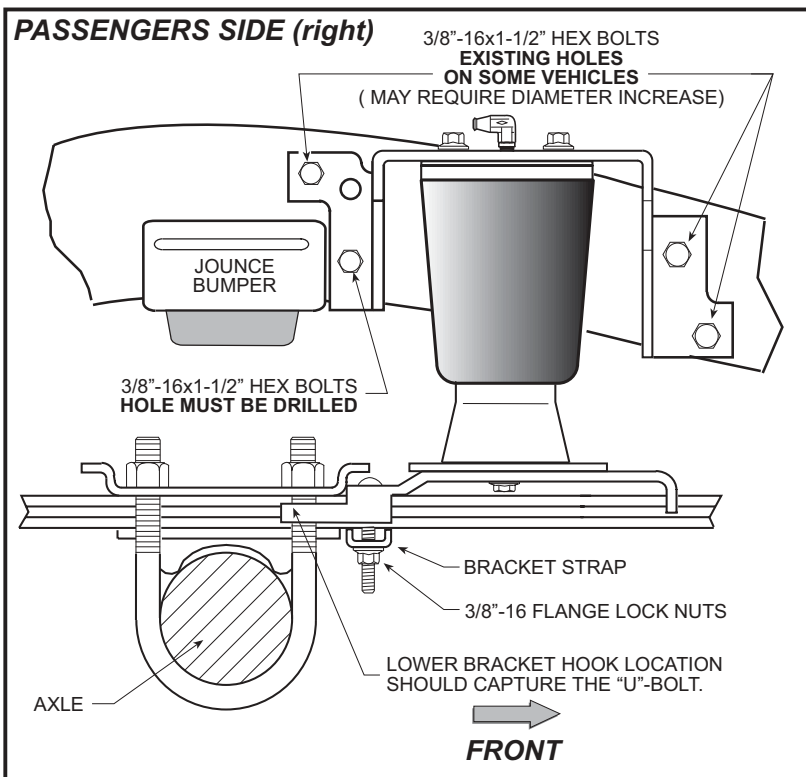
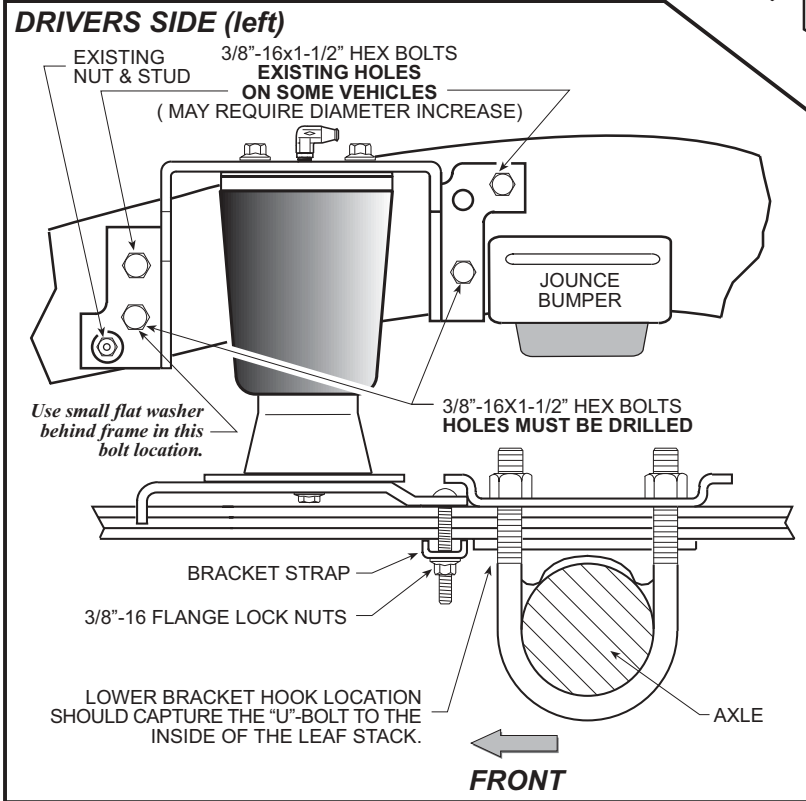

Note 1: Elbow fitting may point in various directions depending upon inflation valve location.

Note 2: Please take all necessary safety precautions while installing your Sport-Rite kit.

FIGURE "A"

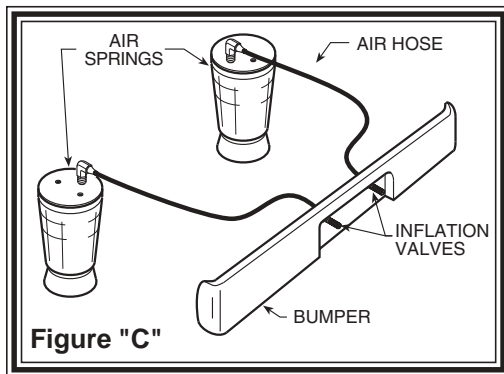

Figure "C"

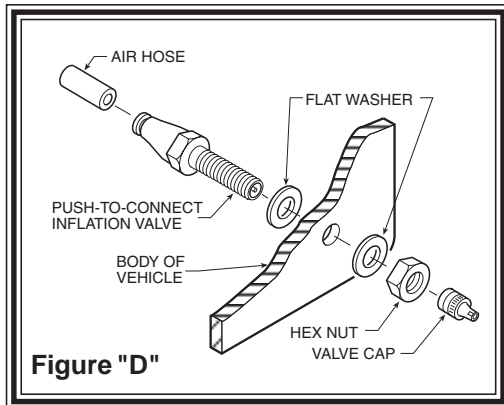

Figure "D"

NOTE:

Once the air helper springs are installed, it is recommended that the vehicle not be lifted by the frame, as over-extension may occur, resulting in damage to the air helper springs. However, should it become necessary to raise the vehicle by the frame, deflate both air helper springs completely.

cleared from the path of the drill. In order to prevent any damage to these lines it is recommended that a piece of wood be placed between the frame rail and the existing lines.

STEP 5 - ATTACHING THE UPPER BRACKET

Once the holes have been drilled or enlarged, attach the upper bracket using the 3/8"-16 x 1-1/2 inch hex bolts, large flat washers and the flanged hex nut, to the frame rail **see Figure "A"**. Large flat washers and nuts to be applied to the back side of the frame rail.

STEP 6 - INSTALLATION OF THE DRIVER'S SIDE ASSEMBLY

Follow steps 1-5 for assembly and installation of the driver's side assembly. Note, reverse any orientations for the driver side installation. **See Figure "A" "Driver's side"** selected upper bracket mounting holes. Large flat washers are to be used behind upper bracket mounting holes except as noted in **Figure "A"** the 3/8" flat washer will be used in the location shown. (**see Figure "A"**).

STEP 1 - PREPARE THE VEHICLE

With the vehicle on a solid, level surface chock the front wheels. Place a jack under the rear axle, jack up and remove the rear wheels. The use of jack stands is required for this installation use jack stands rated for your vehicles weight. Remove the positive battery cable.

STEP 2 - PREASSEMBLE THE RIDE-RITE KIT

Select one air helper spring from your kit. Install the upper right bracket stamped "R" by aligning the threaded holes on the air spring with the holes on the upper bracket. Fasten the upper bracket to the air spring using the 3/8"-16 x 3/4" flanged hex bolt as shown in **Figure "A"**. Install the air fitting as shown in **Figure "A"**. Tighten the air fitting securely to engage the orange thread sealant (make sure the fitting is pointing in the direction of the inflation valve **see Note 1 Figure "A"**). Insert the two 3/8"-16 x 3 1/2" carriage bolts into the lower bracket. Next, attach the lower bracket and disk to the air spring finger tight using the 3/8"-16 x 3/4" flanged hex bolt **see Figure "A"**. Refer to **Figure "A"** for proper orientation of the lower bracket.

STEP 3 - ATTACH LOWER BRACKET TO LEAF SPRING

Place the assembly on the passenger's side on top of the leaf spring stack forward of the axle (**see Figure "A"**). Attach the the lower bracket to the leaf stack using the 3/8"-16 x 3 1/2" carriage bolts installed earlier and bracket strap as shown in **Figure "A"**. Note that the hook on the lower bracket will capture the "U"-bolt. Tighten the lower air spring bolt that attaches the lower bracket to the air spring.

STEP 4 - MARK AND DRILL HOLES IN THE FRAME RAIL

Several existing holes on some vehicles will be used in the frame rail. Refer to **Figure "A"** for positioning of the upper bracket and selected hole locations. Some holes may also need to be drilled or existing holes may need to be enlarged to accept the 3/8"-16x1-1/2" hex bolts (**see Figure "A"**). With the air spring assembly in place, use the upper bracket as a template and drill the holes or enlarge existing holes using a 7/16" drill bit. **Before drilling the holes make sure all electrical, brake and fuel lines are**

STEP 7 - INSTALL THE AIR LINE AND INFLATION VALVE

Uncoil the air tubing and cut it into two equal lengths. *DO NOT FOLD OR KINK THE TUBING.* Try to make the cut as square as possible. Insert one end of the tubing into the elbow fitting installed in the top of the air helper spring. Push the tubing into the fitting as far as possible refer to **Figure "A"**.

Select a location on the vehicle for the air inflation valves. The location can be on the bumper or the body of the vehicle, as long as it is in a protected location so the valve will not be damaged, but maintain accessibility for the air chuck (*see Figure "B"*). Drill a 5/16" hole and install the air inflation valve using two 5/16" flat washers per valve as supports (*see Figure "C"*). Run the tubing from the air helper spring to the inflation valve, routing it to avoid direct heat from the engine, exhaust pipe, and away from sharp edges. The air line tubing should not be bent or curved sharply as it may buckle with age. Secure the tubing in place with the nylon ties provided. Push the end of the air line tubing into the inflation valve as illustrated (*see Figure "C"*).

STEP 8 - CHECK THE AIR SYSTEM

Once the inflation valves are installed inflate the air helper springs to *50 P.S.I.* and check the fittings for air leaks with an applied solution of soap and water. If a leak is detected at a tubing connection then check to make sure that the tube is cut as square as possible and that it is pushed completely into the fitting. The tubing can easily be removed from the fittings by pushing the collar towards the body of the fitting and then pulling out the tube. If a leak is detected where the brass straight fitting screws into the spring, remove the tubing, then screw the straight fitting into the spring one additional turn or until the leak stops. Reinstall the tubing and reinflate the air springs and check for leaks as noted above. Further information on troubleshooting can be found in the General Operation Instruction book included with this kit.

This now completes the installation. Install the wheels and torque the lug nuts to the manufactures specifications. Raise the vehicle by the rear axle and remove the jack stands and lower the vehicle back onto the ground. Re-attach the positive battery cable and remove the wheel chocks from the front wheels. Before proceeding, check once again to be sure you have proper clearance around the air springs. With a load on your vehicle and the air helper springs inflated, you must have at least 1/2" clearance around the air springs. As a general rule, the Sport-Rite Air Helper Springs will support approximately 30 lbs. of load for each P.S.I. of inflation pressure (per pair). For example, 50 P.S.I. of inflation pressure will support a load of approximately 1500 lbs. per pair of air helper springs. *FOR BEST RIDE* use only enough air pressure in the air helper springs to level the vehicle when viewed from the side (front to rear). This amount will vary depending on the load, location of load, condition of existing suspension and personal preference.

NOTE:

Too much air pressure in the air helper springs will result in a firmer ride, while too little air pressure will allow the air helper spring to bottom out over rough conditions. Too little air pressure will also not provide the improvement in handling that is possible. ***TO PREVENT POSSIBLE DAMAGE MAINTAIN A MINIMUM OF 10 P.S.I. IN THE SPORT-RITE AIR HELPER SPRINGS AT ALL TIMES.***

